

SECTION 1 (Maximum Marks: 12)

- This section contains **FOUR (04)** questions.
- Each question has **FOUR** options (A), (B), (C) and (D). **ONLY ONE** of these four options is the correct answer.
- For each question, choose the option corresponding to the correct answer.
- Answer to each question will be evaluated according to the following marking scheme:
Full Marks : +3 If **ONLY** the correct option is chosen;
Zero Marks : 0 If none of the options is chosen (i.e. the question is unanswered);
Negative Marks : -1 In all other cases.

Q.1 Let $f(x)$ be a continuously differentiable function on the interval $(0, \infty)$ such that $f(1) = 2$ and

$$\lim_{t \rightarrow x} \frac{t^{10} f(x) - x^{10} f(t)}{t^9 - x^9} = 1$$

for each $x > 0$. Then, for all $x > 0$, $f(x)$ is equal to

- (A) $\frac{31}{11x} - \frac{9}{11}x^{10}$ (B) $\frac{9}{11x} + \frac{13}{11}x^{10}$
 (C) $\frac{-9}{11x} + \frac{31}{11}x^{10}$ (D) $\frac{13}{11x} + \frac{9}{11}x^{10}$

Q.2 A student appears for a quiz consisting of only true-false type questions and answers all the questions. The student knows the answers of some questions and guesses the answers for the remaining questions. Whenever the student knows the answer of a question, he gives the correct answer. Assume that the probability of the student giving the correct answer for a question, given that he has guessed it, is $\frac{1}{2}$. Also assume that the probability of the answer for a question being guessed, given that the student's answer is correct, is $\frac{1}{6}$. Then the probability that the student knows the answer of a randomly chosen question is

- (A) $\frac{1}{12}$ (B) $\frac{1}{7}$ (C) $\frac{5}{7}$ (D) $\frac{5}{12}$

Q.3 Let $\frac{\pi}{2} < x < \pi$ be such that $\cot x = \frac{-5}{\sqrt{11}}$. Then

$$\left(\sin \frac{11x}{2}\right)(\sin 6x - \cos 6x) + \left(\cos \frac{11x}{2}\right)(\sin 6x + \cos 6x)$$

is equal to

- (A) $\frac{\sqrt{11}-1}{2\sqrt{3}}$ (B) $\frac{\sqrt{11}+1}{2\sqrt{3}}$
 (C) $\frac{\sqrt{11}+1}{3\sqrt{2}}$ (D) $\frac{\sqrt{11}-1}{3\sqrt{2}}$

Q.4 Consider the ellipse $\frac{x^2}{9} + \frac{y^2}{4} = 1$. Let $S(p, q)$ be a point in the first quadrant such that

$\frac{p^2}{9} + \frac{q^2}{4} > 1$. Two tangents are drawn from S to the ellipse, of which one meets the ellipse at one end point of the minor axis and the other meets the ellipse at a point T in the fourth quadrant. Let R be the vertex of the ellipse with positive x -coordinate and O be the center of the ellipse. If the area of the triangle ΔORT is $\frac{3}{2}$, then which of the following options is correct?

- (A) $q = 2, p = 3\sqrt{3}$ (B) $q = 2, p = 4\sqrt{3}$
 (C) $q = 1, p = 5\sqrt{3}$ (D) $q = 1, p = 6\sqrt{3}$

SECTION 2 (Maximum Marks: 12)

- This section contains **THREE (03)** questions.
- Each question has **FOUR** options (A), (B), (C) and (D). **ONE OR MORE THAN ONE** of these four option(s) is(are) correct answer(s).
- For each question, choose the option(s) corresponding to (all) the correct answer(s).
- Answer to each question will be evaluated according to the following marking scheme:
 - Full Marks* : +4 **ONLY** if (all) the correct option(s) is(are) chosen;
 - Partial Marks* : +3 If all the four options are correct but **ONLY** three options are chosen;
 - Partial Marks* : +2 If three or more options are correct but **ONLY** two options are chosen, both of which are correct;
 - Partial Marks* : +1 If two or more options are correct but **ONLY** one option is chosen and it is a correct option;
 - Zero Marks* : 0 If none of the options is chosen (i.e. the question is unanswered);
 - Negative Marks* : -2 In all other cases.
- For example, in a question, if (A), (B) and (D) are the **ONLY** three options corresponding to correct answers, then
 - choosing **ONLY** (A), (B) and (D) will get +4 marks;
 - choosing **ONLY** (A) and (B) will get +2 marks;
 - choosing **ONLY** (A) and (D) will get +2 marks;
 - choosing **ONLY** (B) and (D) will get +2 marks;
 - choosing **ONLY** (A) will get +1 mark;
 - choosing **ONLY** (B) will get +1 mark;
 - choosing **ONLY** (D) will get +1 mark;
 - choosing no option (i.e. the question is unanswered) will get 0 marks; and
 - choosing any other combination of options will get -2 marks.

Q.5 Let $S = \{a + b\sqrt{2} : a, b \in \mathbb{Z}\}$, $T_1 = \{(-1 + \sqrt{2})^n : n \in \mathbb{N}\}$, and $T_2 = \{(1 + \sqrt{2})^n : n \in \mathbb{N}\}$.

Then which of the following statements is (are) TRUE?

- (A) $\mathbb{Z} \cup T_1 \cup T_2 \subset S$
- (B) $T_1 \cap \left(0, \frac{1}{2024}\right) = \phi$, where ϕ denotes the empty set.
- (C) $T_2 \cap (2024, \infty) \neq \phi$
- (D) For any given $a, b \in \mathbb{Z}$, $\cos(\pi(a + b\sqrt{2})) + i \sin(\pi(a + b\sqrt{2})) \in \mathbb{Z}$ if and only if $b = 0$, where $i = \sqrt{-1}$.

Q.6 Let \mathbb{R}^2 denote $\mathbb{R} \times \mathbb{R}$. Let

$$S = \{(a, b, c) : a, b, c \in \mathbb{R} \text{ and } ax^2 + 2bxy + cy^2 > 0 \text{ for all } (x, y) \in \mathbb{R}^2 - \{(0, 0)\}\}.$$

Then which of the following statements is (are) TRUE?

(A) $\left(2, \frac{7}{2}, 6\right) \in S$

(B) If $\left(3, b, \frac{1}{12}\right) \in S$, then $|2b| < 1$.

(C) For any given $(a, b, c) \in S$, the system of linear equations

$$ax + by = 1$$

$$bx + cy = -1$$

has a unique solution.

(D) For any given $(a, b, c) \in S$, the system of linear equations

$$(a+1)x + by = 0$$

$$bx + (c+1)y = 0$$

has a unique solution.

Q.7 Let \mathbb{R}^3 denote the three-dimensional space. Take two points $P = (1, 2, 3)$ and $Q = (4, 2, 7)$. Let $\text{dist}(X, Y)$ denote the distance between two points X and Y in \mathbb{R}^3 . Let

$$S = \{X \in \mathbb{R}^3 : (\text{dist}(X, P))^2 - (\text{dist}(X, Q))^2 = 50\} \text{ and}$$

$$T = \{Y \in \mathbb{R}^3 : (\text{dist}(Y, Q))^2 - (\text{dist}(Y, P))^2 = 50\}.$$

Then which of the following statements is (are) TRUE?

(A) There is a triangle whose area is 1 and all of whose vertices are from S .

(B) There are two distinct points L and M in T such that each point on the line segment LM is also in T .

(C) There are infinitely many rectangles of perimeter 48, two of whose vertices are from S and the other two vertices are from T .

(D) There is a square of perimeter 48, two of whose vertices are from S and the other two vertices are from T .

SECTION 3 (Maximum Marks: 24)

- This section contains **SIX (06)** questions.
- The answer to each question is a **NON-NEGATIVE INTEGER**.
- For each question, enter the correct integer corresponding to the answer using the mouse and the on-screen virtual numeric keypad in the place designated to enter the answer.
- Answer to each question will be evaluated according to the following marking scheme:
Full Marks : +4 If **ONLY** the correct integer is entered;
Zero Marks : 0 In all other cases.

Q.8 Let $a = 3\sqrt{2}$ and $b = \frac{1}{5^{1/6}\sqrt{6}}$. If $x, y \in \mathbb{R}$ are such that

$$3x + 2y = \log_a (18)^{\frac{5}{4}} \quad \text{and}$$

$$2x - y = \log_b (\sqrt{1080}),$$

then $4x + 5y$ is equal to _____.

Q.9 Let $f(x) = x^4 + ax^3 + bx^2 + c$ be a polynomial with real coefficients such that $f(1) = -9$. Suppose that $i\sqrt{3}$ is a root of the equation $4x^3 + 3ax^2 + 2bx = 0$, where $i = \sqrt{-1}$. If $\alpha_1, \alpha_2, \alpha_3$, and α_4 are all the roots of the equation $f(x) = 0$, then $|\alpha_1|^2 + |\alpha_2|^2 + |\alpha_3|^2 + |\alpha_4|^2$ is equal to _____.

Q.10 Let $S = \left\{ A = \begin{pmatrix} 0 & 1 & c \\ 1 & a & d \\ 1 & b & e \end{pmatrix} : a, b, c, d, e \in \{0, 1\} \text{ and } |A| \in \{-1, 1\} \right\}$, where $|A|$ denotes the determinant of A . Then the number of elements in S is _____.

Q.11 A group of 9 students, s_1, s_2, \dots, s_9 , is to be divided to form three teams X, Y , and Z of sizes 2, 3, and 4, respectively. Suppose that s_1 cannot be selected for the team X , and s_2 cannot be selected for the team Y . Then the number of ways to form such teams, is _____.

- Q.12 Let $\overrightarrow{OP} = \frac{\alpha-1}{\alpha}\hat{i} + \hat{j} + \hat{k}$, $\overrightarrow{OQ} = \hat{i} + \frac{\beta-1}{\beta}\hat{j} + \hat{k}$ and $\overrightarrow{OR} = \hat{i} + \hat{j} + \frac{1}{2}\hat{k}$ be three vectors, where $\alpha, \beta \in \mathbb{R} - \{0\}$ and O denotes the origin. If $(\overrightarrow{OP} \times \overrightarrow{OQ}) \cdot \overrightarrow{OR} = 0$ and the point $(\alpha, \beta, 2)$ lies on the plane $3x + 3y - z + l = 0$, then the value of l is _____.
- Q.13 Let X be a random variable, and let $P(X = x)$ denote the probability that X takes the value x . Suppose that the points $(x, P(X = x))$, $x = 0, 1, 2, 3, 4$, lie on a fixed straight line in the xy -plane, and $P(X = x) = 0$ for all $x \in \mathbb{R} - \{0, 1, 2, 3, 4\}$. If the mean of X is $\frac{5}{2}$, and the variance of X is α , then the value of 24α is _____.

Learnto

SECTION 4 (Maximum Marks: 12)

- This section contains **FOUR (04)** Matching List Sets.
- Each set has **ONE** Multiple Choice Question.
- Each set has **TWO** lists: **List-I** and **List-II**.
- **List-I** has **Four** entries (P), (Q), (R) and (S) and **List-II** has **Five** entries (1), (2), (3), (4) and (5).
- **FOUR** options are given in each Multiple Choice Question based on **List-I** and **List-II** and **ONLY ONE** of these four options satisfies the condition asked in the Multiple Choice Question.
- Answer to each question will be evaluated according to the following marking scheme:
Full Marks : +3 **ONLY** if the option corresponding to the correct combination is chosen;
Zero Marks : 0 If none of the options is chosen (i.e. the question is unanswered);
Negative Marks : -1 In all other cases.

Q.14 Let α and β be the distinct roots of the equation $x^2 + x - 1 = 0$. Consider the set $T = \{1, \alpha, \beta\}$. For a 3×3 matrix $M = (a_{ij})_{3 \times 3}$, define $R_i = a_{i1} + a_{i2} + a_{i3}$ and $C_j = a_{1j} + a_{2j} + a_{3j}$ for $i = 1, 2, 3$ and $j = 1, 2, 3$.

Match each entry in **List-I** to the correct entry in **List-II**.

- | List-I | List-II |
|---|--------------|
| (P) The number of matrices $M = (a_{ij})_{3 \times 3}$ with all entries in T such that $R_i = C_j = 0$ for all i, j , is | (1) 1 |
| (Q) The number of symmetric matrices $M = (a_{ij})_{3 \times 3}$ with all entries in T such that $C_j = 0$ for all j , is | (2) 12 |
| (R) Let $M = (a_{ij})_{3 \times 3}$ be a skew symmetric matrix such that $a_{ij} \in T$ for $i > j$. Then the number of elements in the set $\left\{ \begin{pmatrix} x \\ y \\ z \end{pmatrix} : x, y, z \in \mathbb{R}, M \begin{pmatrix} x \\ y \\ z \end{pmatrix} = \begin{pmatrix} a_{12} \\ 0 \\ -a_{23} \end{pmatrix} \right\}$ is | (3) infinite |
| (S) Let $M = (a_{ij})_{3 \times 3}$ be a matrix with all entries in T such that $R_i = 0$ for all i . Then the absolute value of the determinant of M is | (4) 6 |
| | (5) 0 |

The correct option is

- (A) (P) \rightarrow (4) (Q) \rightarrow (2) (R) \rightarrow (5) (S) \rightarrow (1)
 (B) (P) \rightarrow (2) (Q) \rightarrow (4) (R) \rightarrow (1) (S) \rightarrow (5)
 (C) (P) \rightarrow (2) (Q) \rightarrow (4) (R) \rightarrow (3) (S) \rightarrow (5)
 (D) (P) \rightarrow (1) (Q) \rightarrow (5) (R) \rightarrow (3) (S) \rightarrow (4)

- Q.15 Let the straight line $y = 2x$ touch a circle with center $(0, \alpha)$, $\alpha > 0$, and radius r at a point A_1 . Let B_1 be the point on the circle such that the line segment A_1B_1 is a diameter of the circle. Let $\alpha + r = 5 + \sqrt{5}$.

Match each entry in **List-I** to the correct entry in **List-II**.

List-I(P) α equals(Q) r equals(R) A_1 equals(S) B_1 equals**List-II**(1) $(-2, 4)$ (2) $\sqrt{5}$ (3) $(-2, 6)$

(4) 5

(5) $(2, 4)$

The correct option is

(A) (P) \rightarrow (4) (Q) \rightarrow (2) (R) \rightarrow (1) (S) \rightarrow (3)(B) (P) \rightarrow (2) (Q) \rightarrow (4) (R) \rightarrow (1) (S) \rightarrow (3)(C) (P) \rightarrow (4) (Q) \rightarrow (2) (R) \rightarrow (5) (S) \rightarrow (3)(D) (P) \rightarrow (2) (Q) \rightarrow (4) (R) \rightarrow (3) (S) \rightarrow (5)

- Q.16 Let $\gamma \in \mathbb{R}$ be such that the lines $L_1 : \frac{x+11}{1} = \frac{y+21}{2} = \frac{z+29}{3}$ and $L_2 : \frac{x+16}{3} = \frac{y+11}{2} = \frac{z+4}{\gamma}$ intersect. Let R_1 be the point of intersection of L_1 and L_2 . Let $O = (0, 0, 0)$, and \hat{n} denote a unit normal vector to the plane containing both the lines L_1 and L_2 .

Match each entry in **List-I** to the correct entry in **List-II**.

List-I

- (P) γ equals
 (Q) A possible choice for \hat{n} is
 (R) $\overline{OR_1}$ equals
 (S) A possible value of $\overline{OR_1} \cdot \hat{n}$ is

List-II

- (1) $-\hat{i} - \hat{j} + \hat{k}$
 (2) $\sqrt{\frac{3}{2}}$
 (3) 1
 (4) $\frac{1}{\sqrt{6}}\hat{i} - \frac{2}{\sqrt{6}}\hat{j} + \frac{1}{\sqrt{6}}\hat{k}$
 (5) $\sqrt{\frac{2}{3}}$

The correct option is

- (A) (P) \rightarrow (3) (Q) \rightarrow (4) (R) \rightarrow (1) (S) \rightarrow (2)
 (B) (P) \rightarrow (5) (Q) \rightarrow (4) (R) \rightarrow (1) (S) \rightarrow (2)
 (C) (P) \rightarrow (3) (Q) \rightarrow (4) (R) \rightarrow (1) (S) \rightarrow (5)
 (D) (P) \rightarrow (3) (Q) \rightarrow (1) (R) \rightarrow (4) (S) \rightarrow (5)

Q.17 Let $f: \mathbb{R} \rightarrow \mathbb{R}$ and $g: \mathbb{R} \rightarrow \mathbb{R}$ be functions defined by

$$f(x) = \begin{cases} x |x| \sin\left(\frac{1}{x}\right), & x \neq 0, \\ 0, & x = 0, \end{cases} \quad \text{and} \quad g(x) = \begin{cases} 1 - 2x, & 0 \leq x \leq \frac{1}{2}, \\ 0, & \text{otherwise.} \end{cases}$$

Let $a, b, c, d \in \mathbb{R}$. Define the function $h: \mathbb{R} \rightarrow \mathbb{R}$ by

$$h(x) = af(x) + b\left(g(x) + g\left(\frac{1}{2} - x\right)\right) + c(x - g(x)) + dg(x), \quad x \in \mathbb{R}.$$

Match each entry in **List-I** to the correct entry in **List-II**.

List-I

- (P) If $a = 0$, $b = 1$, $c = 0$, and $d = 0$, then
 (Q) If $a = 1$, $b = 0$, $c = 0$, and $d = 0$, then
 (R) If $a = 0$, $b = 0$, $c = 1$, and $d = 0$, then
 (S) If $a = 0$, $b = 0$, $c = 0$, and $d = 1$, then

List-II

- (1) h is one-one.
 (2) h is onto.
 (3) h is differentiable on \mathbb{R} .
 (4) the range of h is $[0, 1]$.
 (5) the range of h is $\{0, 1\}$.

The correct option is

- (A) (P) \rightarrow (4) (Q) \rightarrow (3) (R) \rightarrow (1) (S) \rightarrow (2)
 (B) (P) \rightarrow (5) (Q) \rightarrow (2) (R) \rightarrow (4) (S) \rightarrow (3)
 (C) (P) \rightarrow (5) (Q) \rightarrow (3) (R) \rightarrow (2) (S) \rightarrow (4)
 (D) (P) \rightarrow (4) (Q) \rightarrow (2) (R) \rightarrow (1) (S) \rightarrow (3)

END OF THE QUESTION PAPER

SECTION 1 (Maximum Marks: 12)

- This section contains **FOUR (04)** questions.
- Each question has **FOUR** options (A), (B), (C) and (D). **ONLY ONE** of these four options is the correct answer.
- For each question, choose the option corresponding to the correct answer.
- Answer to each question will be evaluated according to the following marking scheme:
Full Marks : +3 If **ONLY** the correct option is chosen;
Zero Marks : 0 If none of the options is chosen (i.e. the question is unanswered);
Negative Marks : -1 In all other cases.

- Q.1 A dimensionless quantity is constructed in terms of electronic charge e , permittivity of free space ϵ_0 , Planck's constant h , and speed of light c . If the dimensionless quantity is written as $e^\alpha \epsilon_0^\beta h^\gamma c^\delta$ and n is a non-zero integer, then $(\alpha, \beta, \gamma, \delta)$ is given by
- (A) $(2n, -n, -n, -n)$ (B) $(n, -n, -2n, -n)$
 (C) $(n, -n, -n, -2n)$ (D) $(2n, -n, -2n, -2n)$
- Q.2 An infinitely long wire, located on the z -axis, carries a current I along the $+z$ -direction and produces the magnetic field \vec{B} . The magnitude of the line integral $\int \vec{B} \cdot d\vec{l}$ along a straight line from the point $(-\sqrt{3}a, a, 0)$ to $(a, a, 0)$ is given by
- [μ_0 is the magnetic permeability of free space.]
- (A) $7\mu_0 I/24$ (B) $7\mu_0 I/12$ (C) $\mu_0 I/8$ (D) $\mu_0 I/6$
- Q.3 Two beads, each with charge q and mass m , are on a horizontal, frictionless, non-conducting, circular hoop of radius R . One of the beads is glued to the hoop at some point, while the other one performs small oscillations about its equilibrium position along the hoop. The square of the angular frequency of the small oscillations is given by
- [ϵ_0 is the permittivity of free space.]
- (A) $q^2/(4\pi\epsilon_0 R^3 m)$ (B) $q^2/(32\pi\epsilon_0 R^3 m)$ (C) $q^2/(8\pi\epsilon_0 R^3 m)$ (D) $q^2/(16\pi\epsilon_0 R^3 m)$
- Q.4 A block of mass 5 kg moves along the x -direction subject to the force $F = (-20x + 10)$ N, with the value of x in metre. At time $t = 0$ s, it is at rest at position $x = 1$ m. The position and momentum of the block at $t = (\pi/4)$ s are
- (A) -0.5 m, 5 kg m/s (B) 0.5 m, 0 kg m/s
 (C) 0.5 m, -5 kg m/s (D) -1 m, 5 kg m/s

SECTION 2 (Maximum Marks: 12)

- This section contains **THREE (03)** questions.
- Each question has **FOUR** options (A), (B), (C) and (D). **ONE OR MORE THAN ONE** of these four option(s) is(are) correct answer(s).
- For each question, choose the option(s) corresponding to (all) the correct answer(s).
- Answer to each question will be evaluated according to the following marking scheme:
 - Full Marks* : +4 **ONLY** if (all) the correct option(s) is(are) chosen;
 - Partial Marks* : +3 If all the four options are correct but **ONLY** three options are chosen;
 - Partial Marks* : +2 If three or more options are correct but **ONLY** two options are chosen, both of which are correct;
 - Partial Marks* : +1 If two or more options are correct but **ONLY** one option is chosen and it is a correct option;
 - Zero Marks* : 0 If none of the options is chosen (i.e. the question is unanswered);
 - Negative Marks* : -2 In all other cases.
- For example, in a question, if (A), (B) and (D) are the **ONLY** three options corresponding to correct answers, then
 - choosing **ONLY** (A), (B) and (D) will get +4 marks;
 - choosing **ONLY** (A) and (B) will get +2 marks;
 - choosing **ONLY** (A) and (D) will get +2 marks;
 - choosing **ONLY** (B) and (D) will get +2 marks;
 - choosing **ONLY** (A) will get +1 mark;
 - choosing **ONLY** (B) will get +1 mark;
 - choosing **ONLY** (D) will get +1 mark;
 - choosing no option (i.e. the question is unanswered) will get 0 marks; and
 - choosing any other combination of options will get -2 marks.

- Q.5 A particle of mass m is moving in a circular orbit under the influence of the central force $F(r) = -kr$, corresponding to the potential energy $V(r) = kr^2/2$, where k is a positive force constant and r is the radial distance from the origin. According to the Bohr's quantization rule, the angular momentum of the particle is given by $L = n\hbar$, where $\hbar = h/(2\pi)$, h is the Planck's constant, and n a positive integer. If v and E are the speed and total energy of the particle, respectively, then which of the following expression(s) is(are) correct?

$$(A) r^2 = n\hbar \sqrt{\frac{1}{mk}}$$

$$(B) v^2 = n\hbar \sqrt{\frac{k}{m^3}}$$

$$(C) \frac{L}{mr^2} = \sqrt{\frac{k}{m}}$$

$$(D) E = \frac{n\hbar}{2} \sqrt{\frac{k}{m}}$$

- Q.6 Two uniform strings of mass per unit length μ and 4μ , and length L and $2L$, respectively, are joined at point O, and tied at two fixed ends P and Q, as shown in the figure. The strings are under a uniform tension T . If we define the frequency $\nu_0 = \frac{1}{2L} \sqrt{\frac{T}{\mu}}$, which of the following statement(s) is(are) correct?

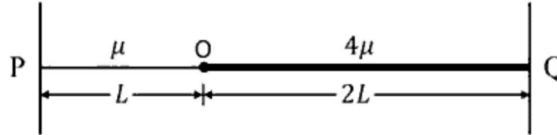

- (A) With a node at O, the minimum frequency of vibration of the composite string is ν_0 .
 (B) With an antinode at O, the minimum frequency of vibration of the composite string is $2\nu_0$.
 (C) When the composite string vibrates at the minimum frequency with a node at O, it has 6 nodes, including the end nodes.
 (D) No vibrational mode with an antinode at O is possible for the composite string.
- Q.7 A glass beaker has a solid, plano-convex base of refractive index 1.60, as shown in the figure. The radius of curvature of the convex surface (SPU) is 9 cm, while the planar surface (STU) acts as a mirror. This beaker is filled with a liquid of refractive index n up to the level QPR. If the image of a point object O at a height of h (OT in the figure) is formed onto itself, then, which of the following option(s) is(are) correct?

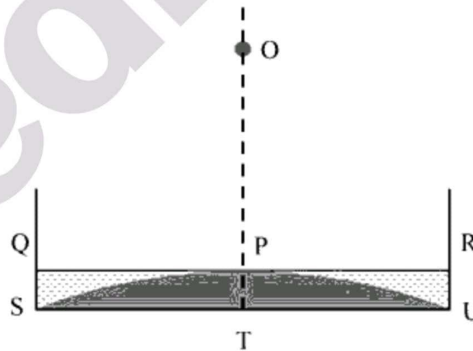

- (A) For $n = 1.42$, $h = 50$ cm. (B) For $n = 1.35$, $h = 36$ cm.
 (C) For $n = 1.45$, $h = 65$ cm. (D) For $n = 1.48$, $h = 85$ cm.

SECTION 3 (Maximum Marks: 24)

- This section contains **SIX (06)** questions.
- The answer to each question is a **NON-NEGATIVE INTEGER**.
- For each question, enter the correct integer corresponding to the answer using the mouse and the on-screen virtual numeric keypad in the place designated to enter the answer.
- Answer to each question will be evaluated according to the following marking scheme:
Full Marks : +4 If **ONLY** the correct integer is entered;
Zero Marks : 0 In all other cases.

- Q.8 The specific heat capacity of a substance is temperature dependent and is given by the formula $C = kT$, where k is a constant of suitable dimensions in SI units, and T is the absolute temperature. If the heat required to raise the temperature of 1 kg of the substance from -73°C to 27°C is nk , the value of n is _____.

[Given: $0\text{ K} = -273^\circ\text{C}$.]

- Q.9 A disc of mass M and radius R is free to rotate about its vertical axis as shown in the figure. A battery operated motor of negligible mass is fixed to this disc at a point on its circumference. Another disc of the same mass M and radius $R/2$ is fixed to the motor's thin shaft. Initially, both the discs are at rest. The motor is switched on so that the smaller disc rotates at a uniform angular speed ω . If the angular speed at which the large disc rotates is ω/n , then the value of n is _____.

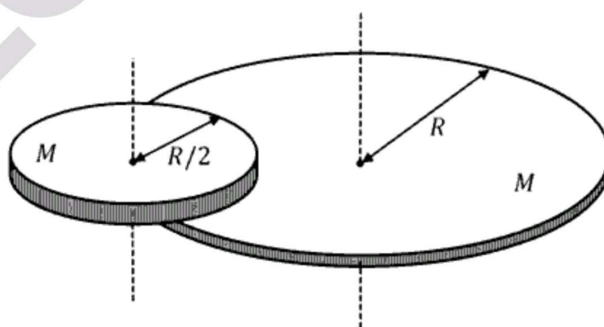

- Q.10 A point source S emits unpolarized light uniformly in all directions. At two points A and B , the ratio $r = I_A/I_B$ of the intensities of light is 2. If a set of two polaroids having 45° angle between their pass-axes is placed just before point B , then the new value of r will be _____.

- Q.11 A source (S) of sound has frequency 240 Hz. When the observer (O) and the source move towards each other at a speed v with respect to the ground (as shown in Case 1 in the figure), the observer measures the frequency of the sound to be 288 Hz. However, when the observer and the source move away from each other at the same speed v with respect to the ground (as shown in Case 2 in the figure), the observer measures the frequency of sound to be n Hz. The value of n is _____.

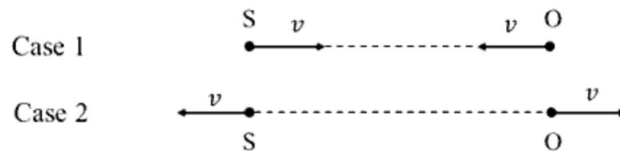

- Q.12 Two large, identical water tanks, 1 and 2, kept on the top of a building of height H , are filled with water up to height h in each tank. Both the tanks contain an identical hole of small radius on their sides, close to their bottom. A pipe of the same internal radius as that of the hole is connected to tank 2, and the pipe ends at the ground level. When the water flows from the tanks 1 and 2 through the holes, the times taken to empty the tanks are t_1 and t_2 , respectively. If $H = \left(\frac{16}{9}\right)h$, then the ratio t_1/t_2 is _____.
- Q.13 A thin uniform rod of length L and certain mass is kept on a frictionless horizontal table with a massless string of length L fixed to one end (top view is shown in the figure). The other end of the string is pivoted to a point O. If a horizontal impulse P is imparted to the rod at a distance $x = L/n$ from the mid-point of the rod (see figure), then the rod and string revolve together around the point O, with the rod remaining aligned with the string. In such a case, the value of n is _____.

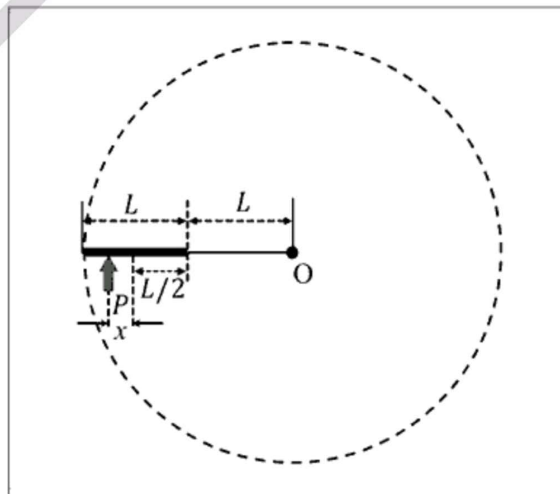

SECTION 4 (Maximum Marks: 12)

- This section contains **FOUR (04)** Matching List Sets.
- Each set has **ONE** Multiple Choice Question.
- Each set has **TWO** lists: **List-I** and **List-II**.
- **List-I** has **Four** entries (P), (Q), (R) and (S) and **List-II** has **Five** entries (1), (2), (3), (4) and (5).
- **FOUR** options are given in each Multiple Choice Question based on **List-I** and **List-II** and **ONLY ONE** of these four options satisfies the condition asked in the Multiple Choice Question.
- Answer to each question will be evaluated according to the following marking scheme:
Full Marks : +3 **ONLY** if the option corresponding to the correct combination is chosen;
Zero Marks : 0 If none of the options is chosen (i.e. the question is unanswered);
Negative Marks : -1 In all other cases.

- Q.14 One mole of a monatomic ideal gas undergoes the cyclic process $J \rightarrow K \rightarrow L \rightarrow M \rightarrow J$, as shown in the P-T diagram.

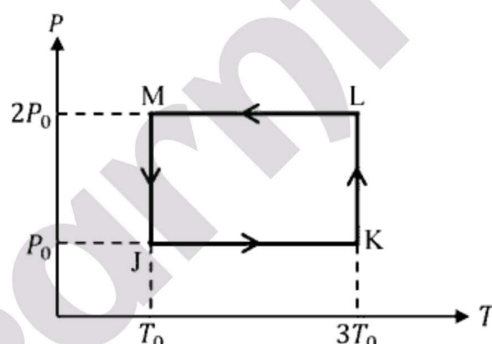

Match the quantities mentioned in List-I with their values in List-II and choose the correct option.

[\mathcal{R} is the gas constant.]

- | List-I | List-II |
|--|--|
| (P) Work done in the complete cyclic process | (1) $\mathcal{R}T_0 - 4\mathcal{R}T_0 \ln 2$ |
| (Q) Change in the internal energy of the gas in the process JK | (2) 0 |
| (R) Heat given to the gas in the process KL | (3) $3\mathcal{R}T_0$ |
| (S) Change in the internal energy of the gas in the process MJ | (4) $-2\mathcal{R}T_0 \ln 2$ |
| | (5) $-3\mathcal{R}T_0 \ln 2$ |
- (A) P \rightarrow 1; Q \rightarrow 3; R \rightarrow 5; S \rightarrow 4 (B) P \rightarrow 4; Q \rightarrow 3; R \rightarrow 5; S \rightarrow 2
 (C) P \rightarrow 4; Q \rightarrow 1; R \rightarrow 2; S \rightarrow 2 (D) P \rightarrow 2; Q \rightarrow 5; R \rightarrow 3; S \rightarrow 4

- Q.15 Four identical thin, square metal sheets, S_1 , S_2 , S_3 and S_4 , each of side a are kept parallel to each other with equal distance d ($\ll a$) between them, as shown in the figure. Let $C_0 = \epsilon_0 a^2/d$, where ϵ_0 is the permittivity of free space.

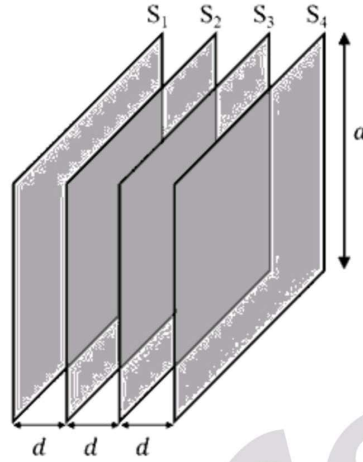

Match the quantities mentioned in List-I with their values in List-II and choose the correct option.

List-I

- (P) The capacitance between S_1 and S_4 , with S_2 and S_3 not connected, is
 (Q) The capacitance between S_1 and S_4 , with S_2 shorted to S_3 , is
 (R) The capacitance between S_1 and S_3 , with S_2 shorted to S_4 , is
 (S) The capacitance between S_1 and S_2 , with S_3 shorted to S_1 , and S_2 shorted to S_4 , is

List-II

- (1) $3C_0$
 (2) $C_0/2$
 (3) $C_0/3$
 (4) $2C_0/3$
 (5) $2C_0$
- (A) P \rightarrow 3; Q \rightarrow 2; R \rightarrow 4; S \rightarrow 5
 (B) P \rightarrow 2; Q \rightarrow 3; R \rightarrow 2; S \rightarrow 1
 (C) P \rightarrow 3; Q \rightarrow 2; R \rightarrow 4; S \rightarrow 1
 (D) P \rightarrow 3; Q \rightarrow 2; R \rightarrow 2; S \rightarrow 5

- Q.16 A light ray is incident on the surface of a sphere of refractive index n at an angle of incidence θ_0 . The ray partially refracts into the sphere with angle of refraction ϕ_0 and then partly reflects from the back surface. The reflected ray then emerges out of the sphere after a partial refraction. The total angle of deviation of the emergent ray with respect to the incident ray is α . Match the quantities mentioned in List-I with their values in List-II and choose the correct option.

List-I

- (P) If $n = 2$ and $\alpha = 180^\circ$, then all the possible values of θ_0 will be
 (Q) If $n = \sqrt{3}$ and $\alpha = 180^\circ$, then all the possible values of θ_0 will be
 (R) If $n = \sqrt{3}$ and $\alpha = 180^\circ$, then all the possible values of ϕ_0 will be
 (S) If $n = \sqrt{2}$ and $\theta_0 = 45^\circ$, then all the possible values of α will be

List-II

- (1) 30° and 0°
 (2) 60° and 0°
 (3) 45° and 0°
 (4) 150°
 (5) 0°
- (A) P \rightarrow 5; Q \rightarrow 2; R \rightarrow 1; S \rightarrow 4
 (B) P \rightarrow 5; Q \rightarrow 1; R \rightarrow 2; S \rightarrow 4
 (C) P \rightarrow 3; Q \rightarrow 2; R \rightarrow 1; S \rightarrow 4
 (D) P \rightarrow 3; Q \rightarrow 1; R \rightarrow 2; S \rightarrow 5

- Q.17 The circuit shown in the figure contains an inductor L , a capacitor C_0 , a resistor R_0 and an ideal battery. The circuit also contains two keys K_1 and K_2 . Initially, both the keys are open and there is no charge on the capacitor. At an instant, key K_1 is closed and immediately after this the current in R_0 is found to be I_1 . After a long time, the current attains a steady state value I_2 . Thereafter, K_2 is closed and simultaneously K_1 is opened and the voltage across C_0 oscillates with amplitude V_0 and angular frequency ω_0 .

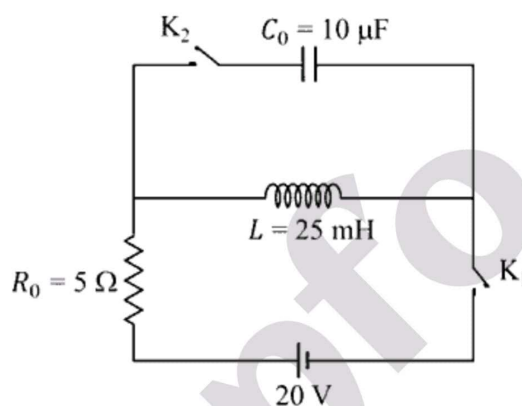

Match the quantities mentioned in List-I with their values in List-II and choose the correct option.

List-I

- (P) The value of I_1 in Ampere is
 (Q) The value of I_2 in Ampere is
 (R) The value of ω_0 in kilo-radians/s is
 (S) The value of V_0 in Volt is

List-II

- (1) 0
 (2) 2
 (3) 4
 (4) 20
 (5) 200

- (A) P \rightarrow 1; Q \rightarrow 3; R \rightarrow 2; S \rightarrow 5
 (C) P \rightarrow 1; Q \rightarrow 3; R \rightarrow 2; S \rightarrow 4

- (B) P \rightarrow 1; Q \rightarrow 2; R \rightarrow 3; S \rightarrow 5
 (D) P \rightarrow 2; Q \rightarrow 5; R \rightarrow 3; S \rightarrow 4

END OF THE QUESTION PAPER

SECTION 1 (Maximum Marks: 12)

- This section contains **FOUR (04)** questions.
- Each question has **FOUR** options (A), (B), (C) and (D). **ONLY ONE** of these four options is the correct answer.
- For each question, choose the option corresponding to the correct answer.
- Answer to each question will be evaluated according to the following marking scheme:

Full Marks : +3 If **ONLY** the correct option is chosen;

Zero Marks : 0 If none of the options is chosen (i.e. the question is unanswered);

Negative Marks : -1 In all other cases.

Q.1 A closed vessel contains 10 g of an ideal gas X at 300 K, which exerts 2 atm pressure. At the same temperature, 80 g of another ideal gas Y is added to it and the pressure becomes 6 atm. The ratio of root mean square velocities of X and Y at 300 K is

- (A) $2\sqrt{2} : \sqrt{3}$ (B) $2\sqrt{2} : 1$ (C) $1 : 2$ (D) $2 : 1$

Q.2 At room temperature, disproportionation of an aqueous solution of *in situ* generated nitrous acid (HNO_2) gives the species

- (A) H_3O^+ , NO_3^- and NO
(B) H_3O^+ , NO_3^- and NO_2
(C) H_3O^+ , NO^- and NO_2
(D) H_3O^+ , NO_3^- and N_2O

- Q.3 Aspartame, an artificial sweetener, is a dipeptide aspartyl phenylalanine methyl ester. The structure of aspartame is

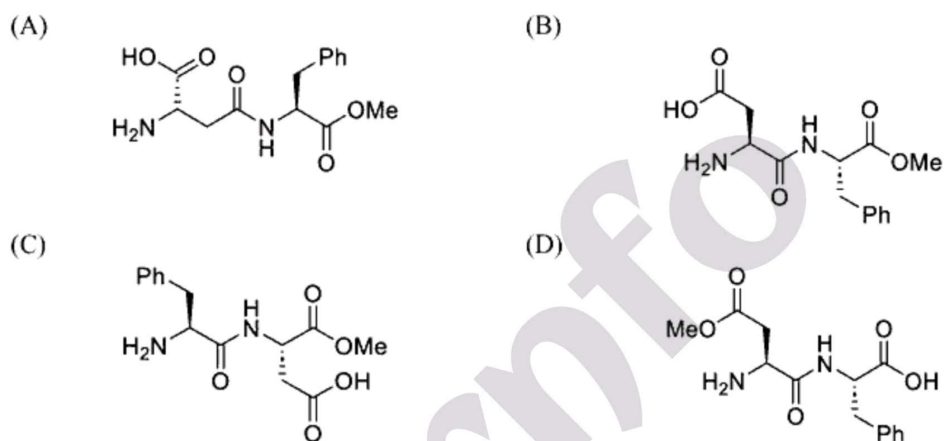
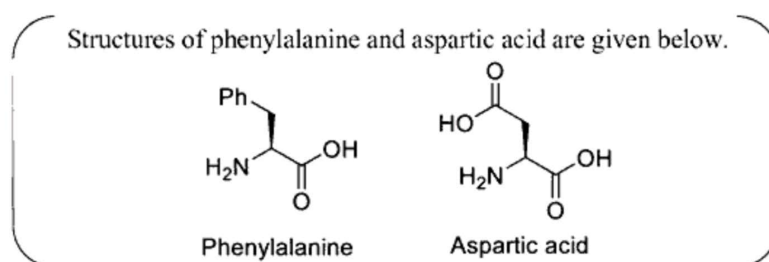

- Q.4 Among the following options, select the option in which each complex in **Set-I** shows geometrical isomerism and the two complexes in **Set-II** are ionization isomers of each other.

[en = $\text{H}_2\text{NCH}_2\text{CH}_2\text{NH}_2$]

- (A) **Set-I:** $[\text{Ni}(\text{CO})_4]$ and $[\text{PdCl}_2(\text{PPh}_3)_2]$
Set-II: $[\text{Co}(\text{NH}_3)_5\text{Cl}]\text{SO}_4$ and $[\text{Co}(\text{NH}_3)_5(\text{SO}_4)]\text{Cl}$
- (B) **Set-I:** $[\text{Co}(\text{en})(\text{NH}_3)_2\text{Cl}_2]$ and $[\text{PdCl}_2(\text{PPh}_3)_2]$
Set-II: $[\text{Co}(\text{NH}_3)_6][\text{Cr}(\text{CN})_6]$ and $[\text{Cr}(\text{NH}_3)_6][\text{Co}(\text{CN})_6]$
- (C) **Set-I:** $[\text{Co}(\text{NH}_3)_3(\text{NO}_2)_3]$ and $[\text{Co}(\text{en})_2\text{Cl}_2]$
Set-II: $[\text{Co}(\text{NH}_3)_5\text{Cl}]\text{SO}_4$ and $[\text{Co}(\text{NH}_3)_5(\text{SO}_4)]\text{Cl}$
- (D) **Set-I:** $[\text{Cr}(\text{NH}_3)_5\text{Cl}]\text{Cl}_2$ and $[\text{Co}(\text{en})(\text{NH}_3)_2\text{Cl}_2]$
Set-II: $[\text{Cr}(\text{H}_2\text{O})_6]\text{Cl}_3$ and $[\text{Cr}(\text{H}_2\text{O})_5\text{Cl}]\text{Cl}_2 \cdot \text{H}_2\text{O}$

SECTION 2 (Maximum Marks: 12)

- This section contains **THREE (03)** questions.
- Each question has **FOUR** options (A), (B), (C) and (D). **ONE OR MORE THAN ONE** of these four option(s) is(are) correct answer(s).
- For each question, choose the option(s) corresponding to (all) the correct answer(s).
- Answer to each question will be evaluated according to the following marking scheme:
 - Full Marks* : +4 **ONLY** if (all) the correct option(s) is(are) chosen;
 - Partial Marks* : +3 If all the four options are correct but **ONLY** three options are chosen;
 - Partial Marks* : +2 If three or more options are correct but **ONLY** two options are chosen, both of which are correct;
 - Partial Marks* : +1 If two or more options are correct but **ONLY** one option is chosen and it is a correct option;
 - Zero Marks* : 0 If none of the options is chosen (i.e. the question is unanswered);
 - Negative Marks* : -2 In all other cases.
- For example, in a question, if (A), (B) and (D) are the **ONLY** three options corresponding to correct answers, then
 - choosing **ONLY** (A), (B) and (D) will get +4 marks;
 - choosing **ONLY** (A) and (B) will get +2 marks;
 - choosing **ONLY** (A) and (D) will get +2 marks;
 - choosing **ONLY** (B) and (D) will get +2 marks;
 - choosing **ONLY** (A) will get +1 mark;
 - choosing **ONLY** (B) will get +1 mark;
 - choosing **ONLY** (D) will get +1 mark;
 - choosing no option (i.e. the question is unanswered) will get 0 marks; and
 - choosing any other combination of options will get -2 marks.

- Q.5 Among the following, the correct statement(s) for electrons in an atom is(are)
- (A) Uncertainty principle rules out the existence of definite paths for electrons.
 - (B) The energy of an electron in 2s orbital of an atom is lower than the energy of an electron that is infinitely far away from the nucleus.
 - (C) According to Bohr's model, the most negative energy value for an electron is given by $n = 1$, which corresponds to the most stable orbit.
 - (D) According to Bohr's model, the magnitude of velocity of electrons increases with increase in values of n .

Q.6 Reaction of *iso*-propylbenzene with O_2 followed by the treatment with H_3O^+ forms phenol and a by-product **P**. Reaction of **P** with 3 equivalents of Cl_2 gives compound **Q**. Treatment of **Q** with $Ca(OH)_2$ produces compound **R** and calcium salt **S**.

The correct statement(s) regarding **P**, **Q**, **R** and **S** is(are)

(A) Reaction of **P** with **R** in the presence of KOH followed by acidification gives

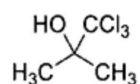

(B) Reaction of **R** with O_2 in the presence of light gives phosgene gas

(C) **Q** reacts with aqueous NaOH to produce Cl_3CCH_2OH and $Cl_3CCOONa$

(D) **S** on heating gives **P**

Q.7 The option(s) in which at least three molecules follow Octet Rule is(are)

(A) CO_2 , C_2H_4 , NO and HCl

(B) NO_2 , O_3 , HCl and H_2SO_4

(C) BCl_3 , NO, NO_2 and H_2SO_4

(D) CO_2 , BCl_3 , O_3 and C_2H_4

SECTION 3 (Maximum Marks: 24)

- This section contains **SIX (06)** questions.
- The answer to each question is a **NON-NEGATIVE INTEGER**.
- For each question, enter the correct integer corresponding to the answer using the mouse and the on-screen virtual numeric keypad in the place designated to enter the answer.
- Answer to each question will be evaluated according to the following marking scheme:
Full Marks : +4 If **ONLY** the correct integer is entered;
Zero Marks : 0 In all other cases.

- Q.8 Consider the following volume–temperature (V – T) diagram for the expansion of 5 moles of an ideal monoatomic gas.

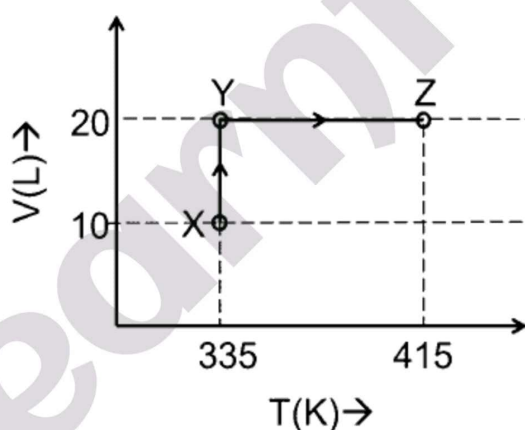

Considering only P–V work is involved, the total change in enthalpy (in Joule) for the transformation of state in the sequence $X \rightarrow Y \rightarrow Z$ is _____.

[Use the given data: Molar heat capacity of the gas for the given temperature range, $C_{v,m} = 12 \text{ J K}^{-1} \text{ mol}^{-1}$ and gas constant, $R = 8.3 \text{ J K}^{-1} \text{ mol}^{-1}$]

Q.9 Consider the following reaction,

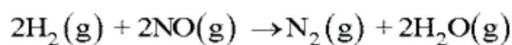

which follows the mechanism given below:

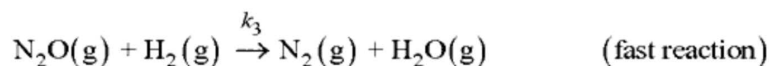
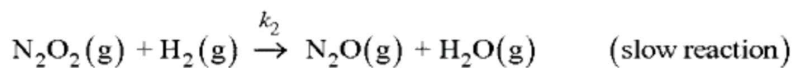

The order of the reaction is _____.

Q.10 Complete reaction of acetaldehyde with excess formaldehyde, upon heating with conc. NaOH solution, gives **P** and **Q**. Compound **P** does not give Tollens' test, whereas **Q** on acidification gives positive Tollens' test. Treatment of **P** with excess cyclohexanone in the presence of catalytic amount of *p*-toluenesulfonic acid (PTSA) gives product **R**. <https://www.pyqonline.com>
Sum of the number of methylene groups (-CH₂-) and oxygen atoms in **R** is _____.

Q.11 Among $\text{V}(\text{CO})_6$, $\text{Cr}(\text{CO})_5$, $\text{Cu}(\text{CO})_3$, $\text{Mn}(\text{CO})_5$, $\text{Fe}(\text{CO})_5$, $[\text{Co}(\text{CO})_3]^{3-}$, $[\text{Cr}(\text{CO})_4]^{4-}$, and $\text{Ir}(\text{CO})_3$, the total number of species isoelectronic with $\text{Ni}(\text{CO})_4$ is _____.

[Given, atomic number: V = 23, Cr = 24, Mn = 25, Fe = 26, Co = 27, Ni = 28, Cu = 29, Ir = 77]

SECTION 4 (Maximum Marks: 12)

- This section contains **FOUR (04)** Matching List Sets.
- Each set has **ONE** Multiple Choice Question.
- Each set has **TWO** lists: **List-I** and **List-II**.
- **List-I** has **Four** entries (P), (Q), (R) and (S) and **List-II** has **Five** entries (1), (2), (3), (4) and (5).
- **FOUR** options are given in each Multiple Choice Question based on **List-I** and **List-II** and **ONLY ONE** of these four options satisfies the condition asked in the Multiple Choice Question.
- Answer to each question will be evaluated according to the following marking scheme:
Full Marks : +3 **ONLY** if the option corresponding to the correct combination is chosen;
Zero Marks : 0 If none of the options is chosen (i.e. the question is unanswered);
Negative Marks : -1 In all other cases.

Learnto

Q.14 In a conductometric titration, small volume of titrant of higher concentration is added stepwise to a larger volume of titrate of much lower concentration, and the conductance is measured after each addition.

The limiting ionic conductivity (Λ_0) values (in $\text{mS m}^2 \text{mol}^{-1}$) for different ions in aqueous solutions are given below:

Ions	Ag^+	K^+	Na^+	H^+	NO_3^-	Cl^-	SO_4^{2-}	OH^-	CH_3COO^-
Λ_0	6.2	7.4	5.0	35.0	7.2	7.6	16.0	19.9	4.1

For different combinations of titrates and titrants given in **List-I**, the graphs of 'conductance' versus 'volume of titrant' are given in **List-II**.

Match each entry in **List-I** with the appropriate entry in **List-II** and choose the correct option.

List-I

(P) Titrate: KCl
Titrant: AgNO_3

(Q) Titrate: AgNO_3
Titrant: KCl

(R) Titrate: NaOH
Titrant: HCl

(S) Titrate: NaOH
Titrant: CH_3COOH

List-II

(1)

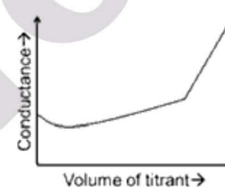

(2)

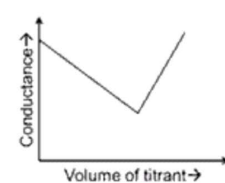

(3)

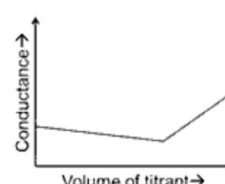

(4)

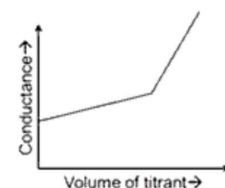

(5)

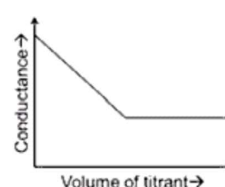

(A) P-4, Q-3, R-2, S-5

(B) P-2, Q-4, R-3, S-1

(C) P-3, Q-4, R-2, S-5

(D) P-4, Q-3, R-2, S-1

Q.15 Based on **VSEPR** model, match the xenon compounds given in **List-I** with the corresponding geometries and the number of lone pairs on xenon given in **List-II** and choose the correct option.

List-I

- (P) XeF_2
- (Q) XeF_4
- (R) XeO_3
- (S) XeO_3F_2

List-II

- (1) Trigonal bipyramidal and two lone pair of electrons
- (2) Tetrahedral and one lone pair of electrons
- (3) Octahedral and two lone pair of electrons
- (4) Trigonal bipyramidal and no lone pair of electrons
- (5) Trigonal bipyramidal and three lone pair of electrons

- (A) P-5, Q-2, R-3, S-1
- (B) P-5, Q-3, R-2, S-4
- (C) P-4, Q-3, R-2, S-1
- (D) P-4, Q-2, R-5, S-3

Learnto

Q.16 **List-I** contains various reaction sequences and **List-II** contains the possible products. Match each entry in **List-I** with the appropriate entry in **List-II** and choose the correct option.

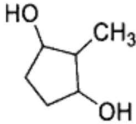
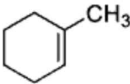
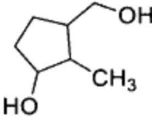
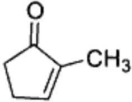
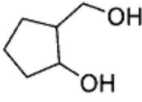
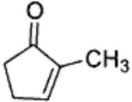
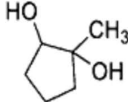
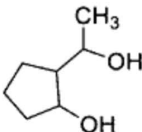
	List-I		List-II
(P)	 i) O_3, Zn ii) aq. $NaOH, \Delta$ iii) ethylene glycol, PTSA —————→ iv) a) BH_3 , b) $H_2O_2, NaOH$ v) H_3O^+ vi) $NaBH_4$	(1)	
(Q)	 i) O_3, Zn ii) aq. $NaOH, \Delta$ —————→ iii) ethylene glycol, PTSA iv) a) BH_3 , b) $H_2O_2, NaOH$ v) H_3O^+ vi) $NaBH_4$	(2)	
(R)	 i) ethylene glycol, PTSA —————→ ii) a) $Hg(OAc)_2, H_2O$, b) $NaBH_4$ iii) H_3O^+ iv) $NaBH_4$	(3)	
(S)	 i) ethylene glycol, PTSA —————→ ii) a) BH_3 , b) $H_2O_2, NaOH$ iii) H_3O^+ iv) $NaBH_4$	(4)	
		(5)	

- (A) P-3, Q-5, R-4, S-1
 (B) P-3, Q-2, R-4, S-1
 (C) P-3, Q-5, R-1, S-4
 (D) P-5, Q-2, R-4, S-1

Q.17 **List-I** contains various reaction sequences and **List-II** contains different phenolic compounds. Match each entry in **List-I** with the appropriate entry in **List-II** and choose the correct option.

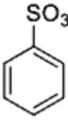
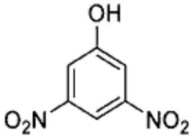
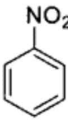
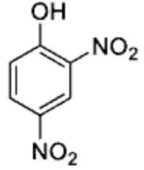
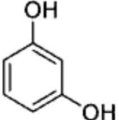
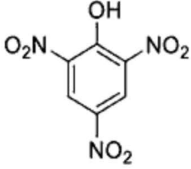
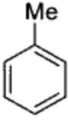
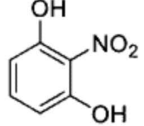
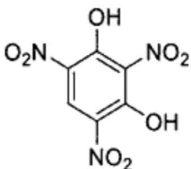
List-I	List-II
(P)  $\xrightarrow[\text{ii) Conc. HNO}_3]{\text{i) molten NaOH, H}_3\text{O}^+}$	(1) 
(Q)  $\xrightarrow[\text{v) Conc. HNO}_3 / \text{Conc. H}_2\text{SO}_4]{\text{i) Conc. HNO}_3 / \text{Conc. H}_2\text{SO}_4, \text{ii) Sn / HCl, iii) NaNO}_2 / \text{HCl, 0 - 5 }^\circ\text{C, iv) H}_2\text{O}}$	(2) 
(R)  $\xrightarrow[\text{iii) H}_3\text{O}^+, \Delta]{\text{i) Conc. H}_2\text{SO}_4, \text{ii) Conc. HNO}_3}$	(3) 
(S)  $\xrightarrow[\text{vi) H}_2\text{O}]{\text{i) a) KMnO}_4 / \text{KOH, } \Delta; \text{ b) H}_3\text{O}^+, \text{ii) Conc. HNO}_3 / \text{Conc. H}_2\text{SO}_4, \Delta, \text{iii) a) SOCl}_2, \text{ b) NH}_3, \text{iv) Br}_2, \text{NaOH, v) NaNO}_2 / \text{HCl, 0 - 5 }^\circ\text{C}}$	(4) 
	(5) 

- (A) P-2, Q-3, R-4, S-5
 (B) P-2, Q-3, R-5, S-1
 (C) P-3, Q-5, R-4, S-1
 (D) P-3, Q-2, R-5, S-4

END OF THE QUESTION PAPER